

---

# SINAR TECHNOLOGY

---

## MOISTURE ANALYZER SUPPORT DOCUMENT

---

# Contents

---

I: How A Sinar Moisture Analyzer Works

II: Routine Maintenance

III: "Do's" and "Don'ts"

IV: Basic Checks and measurements

V: Fault-Finding

VI: Removing Offsets from Product Channels

VII: Error Code Summary

VIII: Full Hardware Calibration

IX: Transferring Calibration Data

X: Servicing Instructions

Appendices

---

# I: How a Sinar Capacitance Moisture Analyzer works

---

## 1. The Theory

The moisture content of a sample is defined as the ratio of mass of free water to the total mass of the sample, and is generally found by weighing the sample, dehydrating it, and re-weighing.

$$\%MC = \frac{\text{Initial Mass} - \text{Final Mass}}{\text{Initial Mass}} \times 100 \quad \text{or} \quad \%MC = \frac{\text{Wet Mass} - \text{Dry Mass}}{\text{Wet Mass}} \times 100$$

It is also possible to measure the moisture content indirectly using the electrical properties of water. This does, in theory, give much quicker readings and speeds up the analytical process. Developing instrumentation that measures these indirect electrical properties is Sinar Technologies business and speciality.

Sinar Technology instrumentation uses the relationship between moisture content and the samples dielectric constant as the basis of measurement. It has been noted for many years that the variation of the dielectric constant of hygroscopic materials against moisture content is approximately linear over a limited but useful range of 0% - 35% moisture content.

The dielectric constant of water is 81, whereas the dielectric constant of most materials of vegetable origin<sup>1</sup> is quite low, ranging from 2.2 to 4.0 in a dry condition. The presence of a very small quantity of water in the material will, therefore, cause a considerable change in the dielectric constant of the combined system. Therefore this direct link between Moisture Content and dielectric content enables Sinar Analyzers to predict, successfully the Moisture Content of a wide range of samples.

## 2. The Problems

The relationship between moisture content and dielectric constant is complicated by several factors. These problems and the answers that Sinar Technology applies to them can be summarised thus:

- ❑ Problem: Inconsistent and high sample temperatures that inherently change the dielectric constant of samples.<sup>2</sup>
- ❑ Answer: Measure the sample temperature (at the same time as the dielectric constant) and compensate accordingly.
  
- ❑ Problem: Uneven distribution of water throughout the sample.
- ❑ Answer: Calibrate using typical samples in the state that they will be measured in practice. For example pre-dried or even freshly harvested.
  
- ❑ Problem: Packing density of the sample
- ❑ Answer: By filling the measurement cell to the same approximate height every time the volume of the sample is kept roughly constant. Use of a loading hopper improves consistency of packing density.

---

<sup>1</sup> For example, paper, wood, or grains

<sup>2</sup> The dielectric constant of most grains and cereals varies approximately linearly with temperature.

Measurement of the sample mass<sup>3</sup> also enables the unit to automatically compensate for differences in sample volume.

- ❑ Problem: Other chemical and physical parameters within a given sample, for example shape, size, protein content etc.
- ❑ Answer: Sinar Technology develops individual calibrations for each significantly different species or differently grown sample of the same species.

### 3. Calibrations

Before any readings can be taken in the field using a Sinar Analyzer, a robust calibration must be established for the commodity that we wish to measure. How might this be achieved?

- ❑ First, obtain samples of the commodity to be measured, which vary in moisture-content one from another. For a variety of wheat, take at least 10 samples differing from each other by at least 1% moisture content. Obviously, moistures depend upon the availability of samples and the moisture range over which you wish to measure.
- ❑ The samples you are using must be measured accurately using the reference method laid down for that particular commodity.<sup>4</sup> This reference method will vary from sample to sample and country to country. Consult Sinar Technology if you require any assistance finding reference methods for a given commodity.
- ❑ The samples are then placed, in turn, into a Sinar moisture meter and the capacitance (dielectric constant) reading is taken.
- ❑ A graph is then constructed of Sinar capacitance reading against reference moisture content for each sample. This can be greatly simplified by using the Sinar MoistureNet calibration software, which automatically predicts all calibration curves.
- ❑ The resulting calibration curve can then be input into a Sinar moisture meter (see elsewhere in this manual for instruction) and used accordingly.

**Note** – In most cases, Sinar Technology is able to supply the Moisture Analyzers ready calibrated to individual requirements. We now have over 20 years of calibration experience in many different commodities and countries.

### 4. What is the unit doing when I take a measurement?

The instrument takes three separate readings and correlates the information ready to be processed by the instrument's microprocessor. These three readings are:

- ❑ The mass of the sample is measured: An oscillating, inertia weight-balance performs this role. The instrument measures the period of oscillation of a spring, which is set in motion once a load has been applied. The resulting period is a function of the mass of the load. This measurement is carried out automatically, in seconds, and the reading used to help compensate for varying sample.
- ❑ The temperature of the sample is measured: A thermistor located within the sample-cell<sup>5</sup> measures sample-temperature many times and the values are compared within the microprocessor. If the

---

<sup>3</sup> using the weight-balance built into each instrument

<sup>4</sup> Example: for Wheat measured in UK the reference method is the oven test – 3 hrs @ 105°C. This is IS0712.

<sup>5</sup> The black bridging plastic insert within the sample-cell cavity

temperature is found to be varying then the microprocessor waits and then takes further readings at one-second intervals. Such a method reduces errors if warm or cold samples (with rapidly changing temperatures) are placed into the analyzer.

- The capacitance (dielectric constant) is measured. The capacitance reading is corrected by the temperature and mass readings simultaneously taken on the sample. The final result (known as Code 0) is applied against the calibration curve to calculate the true moisture content of the sample.

---

## II: Routine Maintenance

---

The precautionary measures below should be employed by all users on a monthly basis or even weekly in dusty or dirty environments. These measures help to maintain best possible performance from the Moisture Analyzer.

### Clean the Male and Female Interfaces

Using a soft cloth and solvent cleaner (e.g., Methanol or Methylated Spirits), clean both the Male and Female Interfaces.<sup>6</sup>

**DO NOT USE WATER AND REMEMBER: DIRTY INTERFACES GIVE INCORRECT READINGS**

Rub both the male and female interface hard to get all grime off. A small M3 sized screwdriver or some such tools can be used to work the cleaning cloth into the female interface.

### Weight Balance Seal

Blow-away any dust and dirt from around the weight balance seal<sup>7</sup>. If this seal gets dirty it impedes movement of the male interface and hence the weight-balance itself. Anything that impedes the weight-balance potentially is a cause of a problem.

### The auto-test

Remember to periodically check to see if the analyzer is still in calibration. To do this turn on instrument and with the sample cell empty, press and release the auto-test button. The instrument will take an empty reading and check all necessary calibration parameters. If all is ok A00 (A000 on the AP6060) will be displayed. The first digit represents capacitance, the second weight (and third too on the AP6060). Calibration drift is occurring if the analyzer displays a result of anything other than a zero. The higher the number, the larger the problem. Any result other than A00 (or A000) means the analyzer requires a full hardware calibration – see section VIII of this manual.

### Clean Cell walls

The internal cell walls should be periodically checked for built up of sample deposit. They may require occasional cleaning. Use a soft cloth and cleaning foam to remove any unwanted deposits from this area. This is particularly relevant if a tacky or sticky sample is being tested.

---

<sup>6</sup> see Figure 1

<sup>7</sup> See Figure 1

---

## III: Do's and Don'ts

---

### DO:

- ❑ Use the plastic hopper to load the sample into the sample cell
- ❑ Fill the sample cell to the bottom edge of the coloured cap
- ❑ Carry out regular routine maintenance – see above
- ❑ Use the analyser on a level, stable surface.

### DON'T:

- ❑ Leave the loading hopper on the instrument whilst taking a reading.
- ❑ Overfill the sample cell.
- ❑ Shake or tap the sample cell after the sample has been loaded.
- ❑ Use excess force when fitting and removing the sample cell.
- ❑ Leave the sample in the cell for any length of time (i.e. more than 2-3 minutes) before re-loading and taking another reading.

---

## IV: Basic Checks And Measurements

---

### 1. Checking the Keypad:

Press all keys on the pad and check for corresponding response from the analyzer. Any dysfunctional key will warrant a keypad change. Simply remove the four screws in the corners of the keypad, lift and then unplug from the main PCB. To fit the new keypad, simply use the removal instructions in reverse.

### 2. Checking the Weight-Balance using 180g sample:

- Prepare a known weight sample using a set of calibrated analytical balances, preferably scales that measure to two decimal places. For all calibration purposes we would recommend Wheat. Wheat flows well, packs well and has an ideal bulk density for calibration purposes. Calibration samples can be purchased from Sinar Technology (part number 1900-6352). Calibration samples are weighed and the capacitance checked by Sinar Technology before the sample bag is sealed. Calibration samples (19006352) form the basis of all calibration work and check routines. Calibration samples must be sealed in an airtight jar or container once opened. Store the sample jar in a cool and dark place. Typically the sample will have a shelf life of two months depending on usage. Remember the sample is pre-weighed and none of the sample can be lost without making it useless.
- To use the sample: Turn on instrument. Using loading hopper, place known a known (180g) sample into the Moisture Analyzer.
- Press the HLW key and wait for six seconds. Result should be 64.5 KG/HLW<sup>8</sup>. If result is outside tolerance, balance is either out of calibration OR non-functional. Proceed to the calibration section of this manual for instruction of calibrating the balance.
- If weight results are INCONSISTANT, i.e. if with a known weight sample (180g) readings drift between tests considerably (more than  $\pm 0.5$ ) then the balance itself may be non-functional. Remove the weight balance cover and re-check the weight readings. A tight seal on the weight balance cover can sometimes interfere with the balance and by removing this cover and taking further readings, you are removing any possible obstruction. If results are still bad once weight-balance cover is removed, a new balance (1900-6241) will be required in the analyzer.

Checking "Code 0" (capacitance or dielectric constant) and or "Percentage Moisture Content" (%H<sub>2</sub>O)

- Place the calibration standard (part no. 1900-6352) into the analyzer using the loading hopper. Turn on the instrument and press 0 followed by the %h20 key. The analyzer will then take a reading on channel 0 (code 0). Results should be  $\pm 0.6$  against the known code 0 (capacitance) of the sample. Sinar Technology packages each calibration sample and denotes the code 0 reading on the sample bag.

---

<sup>8</sup>  $\pm 1.0$  tolerance allowed

- ❑ If code zero result falls outside of acceptable tolerances the analyzer must be re-calibrated for code 0. See instructions later in this manual (section VIII) for details of calibration methods.

#### Checking % Moisture Content on the analyzer

- ❑ Load a known reference Moisture sample into the analyzer using the loading hopper. Select the correct crop or commodity key on the analyzer. Press the percentage Moisture Content (%H<sub>2</sub>O) key and results will be displayed within 6 seconds.
- ❑ Results should be  $\pm 0.3\%$  away from the reference moisture sample. If not other parameters – code 0, weight and temperature should now also be checked.
- ❑ If all parameters (code 0, weight and temperature) are correct but bad moisture results continue, then the crop calibration itself MUST be at fault. The user will then need to either contact Sinar Technology for further assistance OR use Mnet calibration package to check the quality of the calibration curve OR to develop a new calibration.

#### Checking the “Temperature”

- ❑ For this check you will require a calibrated (maybe even certified), digital temperature probe. Such items are available from Sinar Technology.
- ❑ Turn on analyzer and place a sample into the sample cell.
- ❑ Place the digital temperature probe into the analyzer and switch it on. Be sure the place the probe towards the front of the sample cell next to the thermistor block.<sup>9</sup>
- ❑ Press the TEMP key on the analyzer and it will read the temperature of the sample inside the cell. Compare against the reference probe. The result from the analyzer should be within 1°C of the temperature probe.

#### Replacing lost passwords

- ❑ If the ram back up battery fails (falls below 3V) OR if ram chip is removed from analyzer main PCB, the password set inside the unit (held in RAM) maybe lost.
- ❑ If the user has an AP6060 with software above version 4.4 AND a copy of MNET, they can use the calibration software to reset the unit's password. This is done in screen F5 within Mnet. Simply put the AP6060 into remote connection mode (hold down TEMP and turn on unit) AND then press Z on the PC keypad whilst in F5. The analyzer's password will be reset to 123.
- ❑ If however you do not have MNET Software, a password must be entered manually. This is done by putting the instrument into CAL-mode and then entering the following: Once in this mode, enter 278 and press %H<sub>2</sub>O; enter 314 and then press AVE; then enter required password (normally 123) and the press `P` on the AP6060 moisture analyzer key.
- ❑ The password has now been set to 123 and the user can validate this by pressing holding down CAL/AUTO again (immediately after resetting password manually). The unit should display H.CAL after 5 seconds (Hardware Calibration mode). The H.CAL mode is only accessible if a correct password has been entered into the analyzer.

---

<sup>9</sup> See diagram 1

---

# V: Fault Finding

---

## 1. Unit is dead and does not switch on

- ❑ Problem Keypad / Faulty 'ON' button: Feel around "ON" Key area in case the contact is slightly offset and the key is not working. Plug in a working keypad and try again.
- ❑ Power Issues: Check the batteries held beneath the instrument in the rectangular battery box compartment. Is the set of four size C batteries producing 6V? If they do not then replace them. Is the battery polarity as they sit in the battery holder? If not re-arrange. Also check to make sure the batteries are making contact with the ends of the battery holder. Are the power wires onto the Main PCB<sup>10</sup> soldered correctly and are the joints in good condition? Check these connections and re-solder joints in this position as necessary. If the batteries are in good condition, the battery holder itself may be faulty and not delivering 6.0V. If the correct voltage is not being supplied to the PCB (check with meter) and the batteries are ok, replace the battery holder.
- ❑ Poor Interface Contact: Remove the sample cell and try to switch the analyzer on. If the analyzer turns on without the cell, examine the female interface for defects. Replacements may have to be fitted to the analyzer since bad interfaces can cause the analyzer to short if the sample cell 'sticks' halfway down the male interface.
- ❑ Instrument Software / Cell PCB Mismatch: Sample cell PCB version must match the software version within the analyzer. Within the old version of the portable analyzer,<sup>11</sup> V5.2 software matches RECTANGULAR cell PCBs (older units) and V6.4 matches HEXAGONAL cell PCBs (newer units). If the match of cell PCB and software is incorrect, the unit may lock up. A correct EPROM OR cell PCB may have to be fitted to the analyzer to correct such a mismatch. NOTE: All AP6060 have hexagonal cell PCBs and match ALL AP6060 version software. Mismatches as described above only occur on OLD MODEL instruments.
- ❑ Faulty Main PCB: If the above all fail, there may be a problem with the main PCB. Try replacing all removable chips – ram, EPROM and processor to see if the problem can be easily rectified. Look beneath the main PCB for obvious moisture damage. Any discolouring could be a sign of problems. Replace the main PCB with a new item and perform the full hardware calibration sequence. New calibrations will have to be downloaded into the unit, either from another analyzer OR from the MoistureNet calibration software.

## 2. Unit switches on but will not read

- ❑ Broken Weight-Balance Coil: If the analyzer reads temperature and takes a weight reading (by pressing KH/HLW key) but will NOT MEASURE MOISTURE then the most likely cause is a damaged weight balance coil. Remove weight-balance from the analyzer (see service instructions, section X) and check the white and yellow wires for any break. If both wires are OK, measure ohm rating across the weight balance coil.<sup>12</sup> An ohm rating of 80 is typical and a broken coil will display open circuit. An open circuit across the coil will require the weight-balance to be exchanged with a new item.

---

<sup>10</sup> Red, black and orange in top right hand corner of PCB

<sup>11</sup> For example G3, F6, C6 and P25

<sup>12</sup> Measure across white and yellow wires

- ❑ Faulty Keypad: Any of the measurement keys (Temperature, KG/HLW or %H2O Keys) could be faulty. Replace Keypad with working unit and re-test.

### 3. Analyzer displays “ERR 1” message

Error 1 means there is no contact between the Main PCB in the analyzer and the sample-cell. There are a few causes of such an error. Causes and possible cures are listed below:

- ❑ Transit Packing: Make sure the elastic band used as transport packaging (around the male interface) has been removed.
- ❑ Interface Problem: Is the sample-cell sitting firmly on the male interface? Poor interface contact can produce error 1 messages. If the contact between the sample cell and weight balance feels stiff (difficult to remove sample-cell) then replace both the male and the female interface in full. Dirty interfaces may also cause problems – see routine maintenance procedure, section II.
- ❑ Broken Balance Green Wire:<sup>13</sup> The typical cause of an error 1 message is a broken green wire on the weight-balance. Using a meter, check for continuity from the green wire on the main PCB to the lower half of the male interface on the weight-balance. No continuity will mean a break has occurred and the green wire will require repairing OR replacement. Typically the green wire will break just beneath the male interface (where it is soldered onto a small PCB making contact with the male interface) and the problem will be obvious to the naked eye. It may be necessary to remove the weight-balance to locate the problem but once located the problem should be easily rectified.
- ❑ Broken Green Wire within Sample-Cell: A broken green wire within the sample cell will also produce error 1. Remove the coloured cell cap and de-solder the three wires from the cell PCB OR simply unplug the wires at the connector.<sup>14</sup> Make sure the green wire is securely soldered to the tag located inside the cell wall. This wire makes an important contact to the outer cell wall (via the solder tag and screw running through the thermistor block) and must be in good condition.
- ❑ Loose Male Interface: Occasionally the male interface becomes loose after some years of use, despite it being locked onto the centre-spindle of the weight-balance with a locking compound. If the bottom of the male-interface does NOT make contact with the small PCB beneath it (to which the green wire is soldered) then error 1 will occur. If the male interface is found to be loose, it will be necessary to remove the weight-balance from the instrument to tighten it down. When replacing OR tightening the male interface the CORRECT TOOL should always be used. Such tools are available from Sinar Technology.

### 4. Analyzer ‘ticks’ continuously and will not read

- ❑ Faulty Drive Components: Lightly tap the sample cell as analyzer ticks. If the unit gives a reading shortly after tapping the cell, replace the main PCB. The components on the main PCB that drive the weight-balance could be faulty. If the instrument now reads OK, calibrate the instrument with the new main PCB and download any necessary calibrations into the analyzer either from another unit OR the Moisture Net calibration software.
- ❑ Faulty Coil: If the unit continues to “TICK” after a new main PCB has been fitted to the analyzer, replace the original main PCB (since you know it not to be the problem) and examine the weight balance for broken wires. If all is OK then exchange the balance with a new item. This should cure the

---

<sup>13</sup> The green wire carries power from the Main PCB to the sample cell

<sup>14</sup> new, AP6060 model only

continuous ticking problem. Remember exchanging the balance will require the instrument to be calibrated.

## 5. Analyzer reads other than A00 or A01 on auto-test

- Carry out routine maintenance procedure as described in section II previously.
- Instrument Requires Calibration: Check both weight and Code 0 readings with 180g calibration sample as described in section III previously. If any of the parameters are out of specified tolerances, recalibrate instrument as necessary with the calibration sample.

## 6. Analyzer gives Inaccurate moisture readings

7. Carry out routine maintenance procedure.
8. Incorrect Calibration Curve: Check product calibration curve using MoistureNet calibration software. Does the analyzer have the correct calibrations programmed into it for the commodity being analyzed?
9. Unnecessary Biases: Check for offsets (see section VI) in product channels. Remove if necessary.
10. Instrument Out of Calibration: Check Code 0, weight and temperature using the 180g calibration sample and temperature probe. Perform a full hardware calibration if any of the results fall outside acceptable tolerances.

## 7. Analyzer gives varied or erratic readings

- Loose Thermistor Block: Check that the thermistor block is tight (i.e. the screw that passes through it) since this can be crucial. A loose thermistor block CAN sometimes cause drifting Code 0 results and therefore bad moisture results. Feel the thermistor block with a finger and check for any side-ways movement. If it feels loose it will need tightening. To tighten the thermistor block do the following:
  - Remove the cell cap
  - unplug OR de-solder the cell wires (brown, blue, and green)
  - remove the two nuts holding the cell PCB assembly in place
  - Drop the assembly down and out of the cell wall.
  - Using an M3 pozi-screwdriver on the bolt head (on the exterior of the cell wall) and a corresponding spanner on the M3 nut inside the cell wall, tighten the thermistor block.
- Carry out routine maintenance procedure as described in section II.
- Ensure the plastic loading hopper is being used.
- Check that the sample cell is not being overfilled. Only fill to bottom edge of sample cell.
- Check that the cell is not being tapped or shaken after the sample is loaded into it.

## 8. Cannot enter password into analyzer

- ❑ Password Change? Has the password been changed? Enter a new password and try again.
- ❑ Unit Lost Memory: Maybe the password has been lost due to a faulty RAM or low ram-protection battery on the Main PCB. Replace the RAM or protection batteries as required and enter a new password into the analyzer. Programme the password as discussed previously and continue.

---

# VI: Removing Offsets From Product Channels

---

Off sets are biases that can be applied to each calibration curve to either raise OR lower the moisture result that the analyzer produces. In short, the bias shifts the whole calibration curve either up or down so no matter how wet or dry the sample, the sample bias (positive OR negative) will always be automatically applied to the results. If the user needs to quickly fine tune the analyzer's moisture readings up and down and does not have the ability to make new calibration curves using the Mnet calibration software, then the bias function allows them to move results immediately up or down. It can be a most useful function in this situation.

However, if somehow biases get into the crop calibrations by mistake (maybe a user has pressed incorrect buttons by mistake) then they will of course contribute to bad result. The following procedure should be used to remove all biases that are NOT required.

Check to see if an offset is present

- ❑ Switch on the instrument. Press and hold down CAL/AUTO key until unit says CAL. Enter the password that is set to 123 in the factory. Press the `P' key to enter this password.
- ❑ Select the product channel to be selected, i.e. number 1. Then press the HLW key. If there is no bias on the instrument 0.0 will be displayed. Anything else is a bias that will affect final results taken on that commodity channel. A minus symbol will be drawn before the figure if it is a negative bias.
- ❑ To remove the bias OR to indeed enter one, use the UP/DOWN arrows on the keypad to change the value. Once the correct value has been reached, switch off instrument.

Commodity biases can also be viewed using the MoistureNet Calibration Software. The bias for a crop calibration is viewed in F2 screen (single curve transfer). Byte 30 represents the bias in that individual crop calibration. Anything other than a value of 160 (bias of 0.0) in this byte will put a bias into the crop commodity channel.

---

## VII: Error Code Summary

---

- ❑ Error 0: Sample too small (less than 20 grams). Try to use a larger sample. If problem arises with over 20g of sample the instrument may have lost calibration data. In this case check for faulty RAM and low ram-back up battery. Replace faulty component and perform full hardware calibration. Instrument will also require new calibrations to be programmed into it from either another analyzer OR the Moisture Net Calibration Software.
- ❑ Error 1: Sample cell not correctly mounted. See 'FaultFinding' for further suggestions.
- ❑ Error 2: Code 0 too high (over 100.0). Use scale down facility on curve byte 28. Check the corresponding calibration curve using Mnet Calibration software. Calibration curve may have become corrupted. Instrument may require full hardware calibration.
- ❑ Error 3: Code 0 too high at low moisture. ). Use scale down facility on curve byte 28. Check the corresponding calibration curve using Mnet Calibration software. Calibration curve may have become corrupted. Instrument may also require full hardware calibration.
- ❑ Error 4: High moisture reading at low code 0 reading. Shift the curve with byte 30 and check the hardware calibration of analyzer.
- ❑ Error 5: Code 0 is too low for the calibration curve - %H<sub>2</sub>O would be negative. Check hardware calibration and the quality of the calibration curve.
- ❑ Error 6: RS232 communication error. Check both cable connections and RS232 port within the analyzer.
- ❑ Batt: Low battery voltage. Change batteries.

---

## VIII: Full Hardware Calibration

---

You will require a calibration sample (part no. 1900-6352) provided by Sinar Technology, a calibrated (certified if necessary) temperature probe and sample loading Hopper.

Models: AP, G3, C6 and F6

1. Turn ON the instrument.
2. With the instrument empty of sample: Press and Hold Down the CAL/AUTO key. When the instrument says `CAL' enter the password, this is factory set to 123. Press P to enter the password once it has been entered.
3. Press and Hold Down the CAL/AUTO key. The instrument will say H.CAL (Hardware Calibration) after approximately 3 seconds.
4. Press and Hold down the AVERAGE key until the unit starts to take an empty reading - approximately 3 seconds. The unit will display `C1' when complete.
5. Using the sample loading Hopper, place calibration sample carefully into the measuring cell. Now enter the CODE 0 value of the sample as typed on the sample packet. Press the KG/HLW button to enter this value into the analyzer's memory.
6. Place the temperature probe into the sample cell. Put it at the front of the cell near the black THERMISTOR BLOCK. Once the temperature reading has stabilised, enter the value into the instrument. Press the TEMP key once to enter the temperature into the unit's memory.
7. Press and hold the %H2O key until the unit starts to take a reading – you will hear it pulse. When the unit displays `C2' calibration is complete.
8. Check calibration by following procedures outlined in section III.

## Model P25

1. Turn on Analyzer so it says `Hi`.
2. With the unit empty of sample, press the mode key once to go into MODE 1. Type 123 (the password) and press TEMP TWICE. You have now entered the password into the Analyzer.
3. Press and Hold the MODE key until you enter mode two. Mode two is the equivalent of H.CAL illustrated in the previous section. Once in this mode, follow the above procedure from section four.

## Model FPA, FP

1. These units are simple to calibrate with all the actions prompted by the menu on the analyzer.
2. To enter the Hardware Calibration Menu turn on the Analyzer and press the MODE key twice.
3. You will be asked to enter a password, which again is factory set at 123. Enter the password and press the ENTER key.
4. Toggle through the various modes until you reach the Hardware Calibration Menu. Press the CONTINUE key (F1) to enter this menu.
5. Press the RECAL key to perform full calibration and follow the on screen prompts. Remember to enter the CODE 0 value and temperature value of the calibration sample as outlined above in sections 5 and 6 – when prompted by the analyzer.

---

# IX: Transferring Calibration Data

---

The following procedure describes how to download calibrations into a Sinar portable Moisture Analyzer.

## Using MNET Calibration Software

You will require a PC running the MNET<sup>15</sup> Software, a pre-programmed dongle and a computer interface cable. Sinar Technology supplies both the dongle and cable when the MNET software package is purchased.

Set up the MNET calibration software on the PC using the full instructions supplied with the software.

### Models AP6060<sup>16</sup> and C6

1. Run the MNET PC software and connect the Analyzer to the PC using the connection cables provided. Turn on the Moisture Analyzer so it says `HI.'
2. Go into F4 (Curve Set Transfer) in MNET software. This is the CURVE SET TRANSFER MENU. Select the Curve-Set you wish to transfer (refer to MNET Manual) and you are now ready to proceed.
3. On the PC:
  - Hold down the CTRL key on the keyboard and press the `O' key. In this instance `O' stands for OUT.
  - Follow the on-screen prompts: Type Y because you wish to download the information.
4. On the Moisture Analyzer:
  - Press and hold down the CAL / AUTO key until the unit says `CAL.'
  - Type in the password, which is factory set to 123. Press `P' to enter the password.
  - Press the CAL / AUTO key once. The Analyzer will say CO.PA and it is now in Communication Mode. Whilst in this communication mode the AVERAGE key on unit is used to INPUT data into the analyzer and the %H2O to OUTPUT<sup>17</sup>.
  - We are sending from the PC so press the AVERAGE key.
5. The data will stream out of the PC into the Moisture Analyzer. You will see it happening – a number will be descending on the screen. The PC and Analyzer will instruct you when the data has been fully downloaded successfully by saying `PASS.'
6. Remember to always GO OUT before you GO IN. If you are sending from the PC to the unit, press `O' and the final Y (for YES) on the PC before you press AVERAGE (for Input) on the unit. Remember the simple phrase, `OUT BEFORE IN' and data transfers will be easy.

### P25 Model

---

<sup>15</sup> For full instructions on using Mnet Software see the Manual supplied with the software.

<sup>16</sup> AP's using Old Software, pre version 4.4

<sup>17</sup> If you were sending data from the Analyzer to the PC, do as above but instead of using `O' for OUT press `I' on the PC keypad. `I' denotes IN. Remember to use %H2O for OUTPUT on the Moisture Analyzer instead of AVERAGE for input.

1. Mode 4 on the P25 Analyzer is the Communication Mode.
2. To enter mode 4 turn on the Analyzer, turn it on and press the mode once to enter mode 1. Enter the password, which is factory set at 123 and press TEMP twice.
3. Now press the MODE key twice until you reach MODE 4. You are now at point five described in the previous section, where the other Analyzers say `CO.PA`
4. Use the above instructions from point five to transfer and receive data.

## FP6070 and FPA6080

1. Turn on the Analyzer and press the mode key twice. Now enter the unit's password.
2. Press the mode key until you reach the CURVE TRANSFER MENU. Press CONTINUE (F1) to enter this mode. Follow the on-screen instructions. As with the other Analyzers, remember to GO OUT BEFORE YOU GO IN.

## Data Transfer Using Latest Software<sup>18</sup> on AP, FP, FPA and GrainPro.

The software within these newer instruments contains a special `Remote Connection Mode` enabling easier curve data transfer.

1. To enter Remote Mode on the AP6060:
  - With the Analyzer off, hold down the TEMP key and turn on the unit.
  - The unit will say `PLUG` to denote that it has entered into it's Remote Mode.
2. To enter Remote Mode on FP / FPA: With the Analyzer off, hold down the F1 key and turn on the Analyzer. The unit will say `Remote Connection`.
3. Once in remote mode, all commands are made using the MNET calibration software.
4. Make sure the Analyzer is connected to the PC and within the MNET software, press F4 for the Curve Set Transfer Menu.
5. Select the calibration set that you wish to transfer. Press O (for OUT) on the PC keyboard. Type Y for YES because you wish to transfer the data to the moisture meter. MNET will tell you when the data is transferred.

To input data just type I (for IN) on the PC keyboard, and the unit's calibrations will be inputted into the PC.

## From Analyzer to Analyzer

A calibration transfer cable (part no. 1000-2766) is required for such transfers. Such cables are available from Sinar Technology.

1. Both analyzers need to be in Communication Mode and connected via the cable.

To send ONE calibration:

---

<sup>18</sup> Software versions 4.4 and above.

- ❑ On the sending unit, select the commodity channel to output and then press %H20 key (OUT). On the receiving instrument, select the product channel that you wish the calibration to be programmed into and then press Average (IN). Once sent successfully, both analyzers will display PASS on their displays.

To send a CURVE SET:

- ❑ On the sending instrument, select %H20 (OUT) and on the receiving instrument select Average (IN). All calibrations will be sent into the receiving unit. Once successfully transferred the units will display PASS.

---

# X: Service Procedure

---

Some modification to the following procedure may be necessary if any fault becomes apparent with the Analyzer during the procedure. If problems do arise, refer to the 'Fault-Finding' section of this manual for instruction on how to cure the problem.

The engineer will require various tools: batteries (four-size C and ram backup battery), cleaning fluids and cleaning cloths to carry out the service. A copy of Sinar Technologies MoistureNet software will be required for calibration curve transfers. Calibration standards (part no. 1900-6352) will also be required along with a temperature probe in order to perform the Full Hardware Calibration that is an integral part of the instrument Service Procedure.

Procedure:

1. Clean instrument body well with anti-static foam cleaner.
  2. Clean male-interface and female-interface with Isopropanol cleaning fluid.
  3. Check for good inter-connection between the weight-balance and sample cell. Tight fitting OR loose interface connection can produce erratic results and a possible error 1 situation. A change of both male and female interfaces is necessary if the contact is incorrect.
  4. Remove the coloured cell cap. Make sure all components (nuts and bolts etc.) are tight on the cell PCB. Tighten the bolt that runs through the black thermistor block (black plastic item bridging the sample cell walls). This is very important since a loose bolt in this area can introduce errors into the Code 0 readings taken by the analyzer. Tighten both M3 nuts that hold the cell PCB assembly to the cell body inner wall. Replace original cell cap and fix using silicon rubber compound.
  5. Check that all keys on the keypad function correctly. If they do not, replace the keypad.
  6. Remove the four screws holding the keypad in place (in the four-corners of the `pad) and remove it. Clean the interior cavity of instrument, lifting the main PCB to brush underneath. Check quality of all connections to the main PCB, especially the weight balance and battery box interface in the top right hand corner of the PCB. It may be necessary to de-solder the wires from the connector in this area in order to strip the wires and make new connections.
  7. Remove the three M3x6 pan pozi screws holding the weight-balance cover in place and remove it. De-solder the weight-balance on the main PCB, i.e. the white, yellow and green wires in the top right hand corner. Underneath the unit, remove the round plate to allow access to the weight-balance retaining plate. Also remove the rectangular battery box plate – this gives access to the weight-balance wires as they pass through the analyzer. You will see that above the battery box itself, the balance wires are fixed using a wire clip. Remove the wires from this clip.
  8. Remove the three M4 screws holding the weight-balance in place. Extract the weight-balance from the unit and visually inspect. Make sure the support-leg and center-spindle are in the middle of their respective holes. If they are not realign the respective springs to position the leg/spindle in the middle of the hole in the magnet assembly.
- To align the support leg and centre-spindle they will need to be removed from the balance itself. Typically they will require aligning because the weight-balance springs have moved been or been bent by some external force. The weight balance will need to be dis-assembled slowly down to its component parts to allow the springs to be replaced or bent back into shape so that they line up with the corresponding holes in the magnet assembly. Remember that dis-assembly of the weight-balance

is a slow job and patience is required to achieve good results. Always use the correct male interface tool and correct size spanners for all nuts.

9. Check the resistance across the weight-balance coil. To do this, measure the ohms rating across the white and yellow wires. A 70-90 ohm rating is acceptable. Also make sure that no wires are too tight and interfering with the travel of the weight-balance. In particular, make sure the green wire (running to the small PCB beneath the male interface) is not too tight.
10. Replace the four batteries with good quality, alkaline, size C batteries.
11. Replace the square red ram backup battery located on the bottom left hand corner of the main PCB.
12. Replace the weight-balance and then the keypad. Make sure the weight-balance is firmly located in the instrument by the three nuts running through the weight balance retaining plate.
13. Replace both the round and rectangular panels underneath the unit. Use new screws and washers on all exterior fixings - base plates, keypad, weight-balance cover etc.
14. Before replacing the weight-balance cover make sure the sample-cell is sitting level on the Analyzer. If the cell is not sitting level, some modification to the support leg on the balance itself may be necessary.
  - To adjust the support-leg gently push the leg in the direction the cell needs to be leveled. For example, if the sample cell is hanging down too far to the left side of the analyzer, remove the cell and using a suitable implement<sup>19</sup> push the support leg (via its top nut) to the right of the analyzer. Be careful not to push too hard or too much initially. Small gentle movements are preferable. Replace the cell and check to see it is level against the body. If not repeat again.
15. Replace the weight-balance cover once the sample-cell has been aligned.
16. Check and update calibrations from MNET calibration package (see section IX) as necessary.
17. Calibrate and Test the instrument. Oven-tested sample should be passed through the instrument as part of the Final Test procedure. All results should be completed on the Final Test Report (see appendix 3).

---

<sup>19</sup> M3 nut-spinner is ideal



## Appendix 1 – Parts List for Portable Analyzers

<i>Part Number</i>	<i>Description</i>	<i>Instrument</i>
10002766	Calibration transfer cable	All
19006154	Hopper	All
19006200	Thermistor Assembly	All
19006201	Cell Wall	All
19006206	Weight Balance Seal	All
19006208	C6 Keyboard	Old models
19006211	Weight Balance Cover	All
19006213	Battery Holder	All
19006217	Cell Cap (AP)	All
C6 EPROM (Old)	C6 EPROM	C6
19006228	AP Keyboard	AP6060
19006240	Sample cell with tapered interface	AP6060
19006241	Weight Balance	All
19006265	Cell PCB (Dual Frequency)	All
19006276	Main PCB (6060)	All
19006342	Male Interface	All
19006350	Female Interface Assembly (Tapered)	New models
19006352	Calibration Standards	All
19006348	Weight balance seal holder	All
On application	Wired Communication Ports	All
“	Ram Back Up Battery	All
“	Cell Cap Extraction Tool	All
“	Male Interface Weight Balance Tool	All

## Appendix 2

### Conversion Table: Mass (g) to Hectolitre weight.

Mass (g)	HLW
10	3.6
20	7.2
30	10.7
40	14.3
50	17.9
60	21.5
70	25.1
80	28.7
90	32.3
100	35.8
110	39.4
120	43.0
130	46.6
140	50.2
150	53.7
160	57.3
170	60.9
180	64.5
190	68.1
200	71.7
210	75.3
220	78.8
230	82.4
240	86.0
250	89.6
260	93.2

The mass reading (in grams) is calculated from the hectolitre weight by dividing the reading by 0.35833.

Appendix 3: Final Test Result Sheet

Final Test Result Sheet

**Date:**

**Operator's Name:**

<b>Customer Name and Details</b>						
<b>Serial No.</b>						
<b>Unit Type</b>						
Visual Check						
Cell Horizontal						
HLW 180g (64.5) <sup>20</sup>						
HLW 210g (75.3)						
HLW 240g (86.0)						
HLW Assy.						
Code 0:Full <sup>21</sup>						
Code 0 Full						
Refill						
½ Full						
Full - ½ Diff. <sup>22</sup>						
50g Code0 Test						
% Moisture						
% Moisture						
Grain Temp. <sup>23</sup>						
Checksum Unit						
Software Version						
Offset Details						
A000 x 5						
Comments:						
Pass or Fail?						

<sup>20</sup>. HLW SPEC: 180g: 64.0-65.0; 210g: 74.6-75.9; 240g: 85.0-86.0. (All figures are inclusive.)

<sup>21</sup>. CODE 0 Spec. ± 0.4 away from In House Test figure.

<sup>22</sup>. Half-Full CODE 0 Spec. ± 0.4 away from the av. of the two Full Code 0 readings.

<sup>23</sup>. TEMPERATURE Spec. ± 0.5

## Appendix 4: Cables and Port Configuration

### RS232 Port

Pin 1 = RXD data input  
Pin 2 = GND ground  
Pin 3 = TXD Data Output  
Pin 4 = Not used  
Pin 5 = Not used

### Printer Cable

Pin 1 = Pin 2  
Pin 2 = Pin 7  
Pin 3 = Pin 3

5 Pin Din first, then 25 pin D plug to printer

### Calibration transfer Cable

Pin 1 = Pin 3  
Pin 2 = Pin 2  
Pin 3 = Pin 1  
Pin 4 = Pin 5  
Pin 5 = Pin 4

Both 5 Pin Din plugs either end

### PC Calibration Transfer Cable

Pin 1 = Pin 2  
Pin 2 = Pin 7  
Pin 3 = Pin 3

5 pin din (first) to 25-pin D type female connector

### PC / AT Adapter

Pin 1 = Pin 3  
Pin 2 = Pin 5  
Pin 3 = Pin 2

5 pin din (first) to 9 pin D female socket

## Appendix 5: Changing Ram and EPROM Chips

- ❑ Switch off analyzer.
- ❑ Remove the caps and screws from each corner of the keyboard.
- ❑ Remove the keyboard to the right taking care not to put stress on the cable connecting the keyboard to the printed circuit board.
- ❑ Remove the EPROM or RAM microchip gently with a screw driver (or an EPROM removing tool if available).

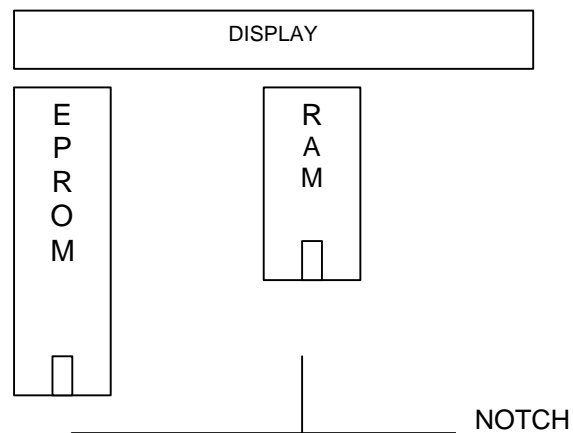
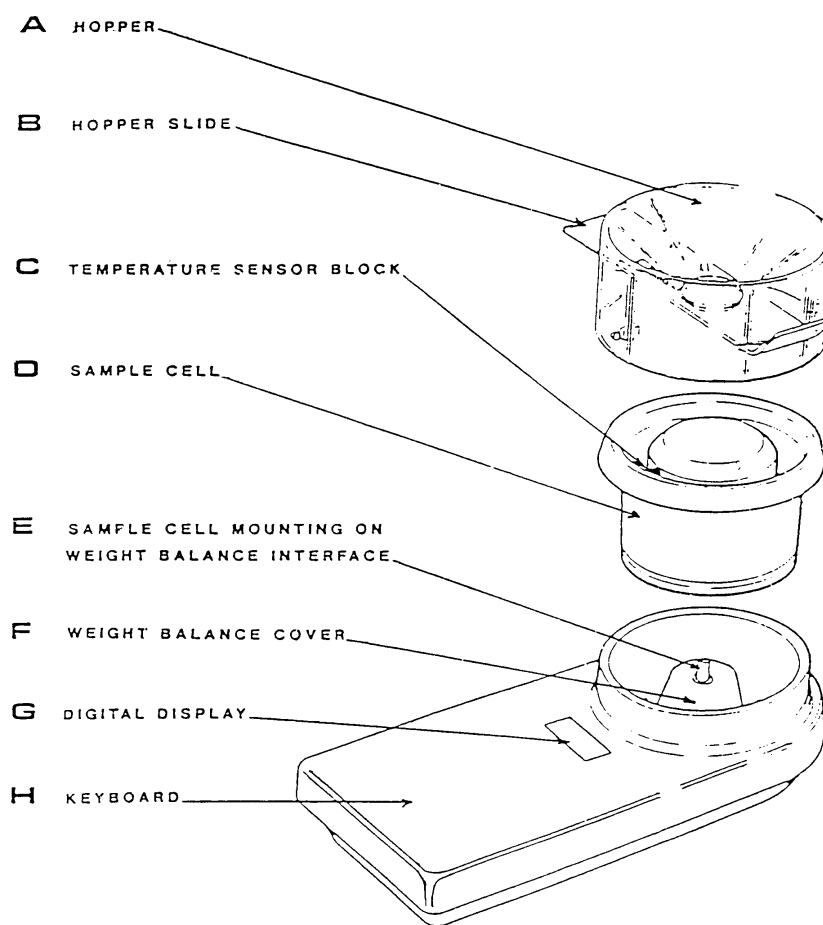

Figure1.

- ❑ Insert the new EPROM or RAM Microchip in to the empty socket taking care that all legs are correctly inserted and the notch is positioned in relation to the display as shown in Figure 1.
- ❑ Check the instrument by switching on. The display should show "-HI-".
- ❑ Replace the keyboard and secure with screws and caps.

## Appendix 6: Portable Analyzer Diagram



## Appendix 7: Sample Cell - Side View

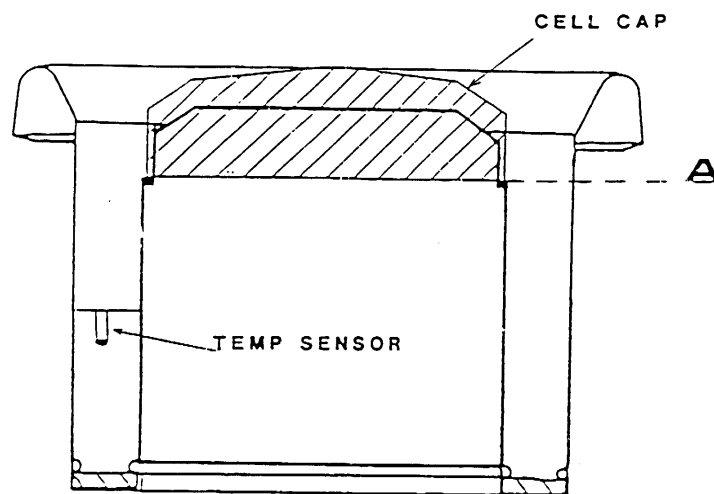

-For optimum reading the cell should be filled to level "A" (bottom of the plastic cell cap).

-The sample should not cover the plastic cell cap or inaccuracies will be introduced.

-Smaller samples are allowed and give slightly lower accuracy.

-The minimum sample is 20 g.

## Appendix 8: Checking an Instruments Checksum

### Why is this Useful?

- ❑ The checksum in the analyser directly reflects the calibration curves programmed into it. Each calibration curve set that is downloaded into the analyser has its own particular CHECKSUM, so there access to this checksum through an analysers keypad is extremely useful if we want to check quickly whether the analyser has retained its calibration data.
- ❑ So, if a user has mentioned that the results from their analyser are unusual, one of the first things to be checked is the analyser CHECKSUM. In other words, you want to make sure that the analyser has the correct calibration curves inside it. Or to put it another way, you want to make sure that the unit's original calibration curves haven't been lost by either the customer altering the data somehow OR component failure such as the RAM CHIP or ram back-up battery.

### Instructions to look at the CHECKSUM inside the analyser:

1. Turn on analyser. Press and hold / down the CAL/AUTO key until the unit says CAL.
  2. Enter the password, which is factory set to 123, and then press P.
  3. Press the CAL/AUTO key once until the instrument says: CO.PA
  4. Now press the P key once and the unit will display first the software version number and then the instrument's checksum.
- ❑ Once you have the CHECKSUM displayed, cross-reference this with your records / customer's curve set on MNET software, to make sure correct and original data is intact.
  - ❑ If the checksum has changed the data from the analyser needs to be downloaded into MNET software for interrogation. You can then see whether the data inside the unit is either totally corrupt (rubbish) or whether the curves have simply been modified against the user application.
  - ❑ If total rubbish is found inside the analyser, typical causes are faulty RAM CHIP components or ram back-up batteries. These batteries should be changed as a matter of course at every service interval.