

+

**Sinar™ Model 6060
AP Moisture Analyzer**



+

Users Manual

**Sinar Technology, Unit 8, Camberley Business Centre,
Bracebridge, Camberley, Surrey, GU15 3DP, ENGLAND
Telephone : +44 (0) 844 745 1999 Fax: +44 (0)1276 63916
email: office@sinar.co.uk Website: www.sinar.co.uk**

+

Version 7.1 2008

On receipt of your new Sinar Model 6060 AP Moisture Analyzer
check the contents of the carton. You should have received:

- One Moisture Analyzer Model 6060
- One Hopper P/N 19006154
- One Calibration sample 19006352
- One Calibration transfer cable 19006917
- One Battery pack P/N 19006215
[Four Alkaline Batteries Type C]
- One Operators manual

Warning;

Before operating your analyzer
remove the transit securing band
around the male interface.

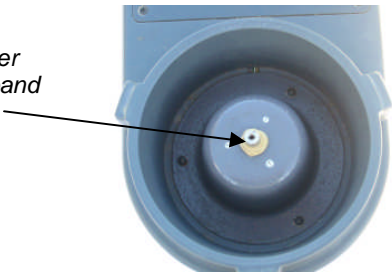

Depending on your location the
analyzer may have been delivered
without the batteries installed. To
install the batteries turn the unit
onto it's back and remove the
four screws securing the
rectangular battery box cover.
Install the batteries as indicated
into the battery box.

Always replace with high quality
long life alkaline Type C battery.

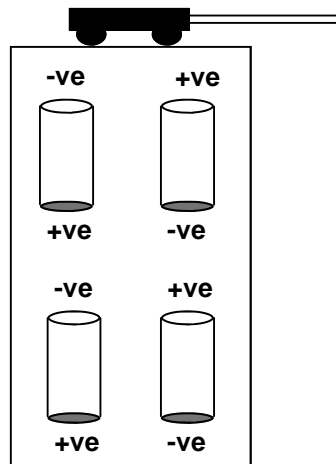

Model 6060AP Moisture Analyzer Specifications

Dimensions:	325 x 164 x 120 mm
Weight:	1.8 kg
Operating environment:	0 to +55°C
Storage temperature:	-20°to+55°C Humidity up to 95% non-condensing.
Construction:	Polyurethane Reaction Injection Moulding.
Display:	3.5 character LCD 15mm high.
Power Supply:	Four C size 1.5 V alkaline batteries. Optional 220/240V 50/60 Supply transformer
Measurement Range:	1-35% moisture, wet basis depending on applications.
Accuracy:	Typical standard deviation 0.3 for moisture (dependent on application and moisture level) and within 1.0 kg for hectolitre (bushel) weight.
Repeatability:	Standard deviation 0.05 to 0.15 (dependant on application).
Weight balance:	Oscillating weight balance. Measures and corrects for weights between 20-240 grams.
Temperature correction:	Thermistor sensor. The correction is software programmable within the range 1– 40°C
Full cell:	290 ml volume.
Bias facility:	Moisture content and hectolitre (bushel) weight readings can be biased in increments of 0.1.
Temperature:	°C or °F.
Specific weight:	Hectolitre or Bushel weight readings.
Memory:	EPROM and RAM.
Printer output:	RS232C

SET UP CHECKS [Hardware settings]

To check that the instrument is in good working order the three sensors, i.e, Temperature, Weight and Capacitance should be checked as follows:

Temperature

Pour the sample into the cell and leave for 30 seconds so that the sample and cell temperature are in equilibrium. Check temperature of grain using an accurate thermometer. Switch on instrument and press TEMP. The two readings should not differ by more than 0.5°C.

Weight

The weight balance is checked using a sample of wheat weighing 180 grams. Any 180g wheat sample should read 64.5 kg/hi \pm 0.5 when the kg/hi key is pressed.

The weight balance should be reset if **180g weighs less than** 64.0 kg/hi or greater than 65.0 kg/hi.

Capacitance

This is checked using a capacitance reference sample. With the sample in the cell press 0 and then press %H₂O. The result should be no greater than \pm 0.3 from the value of the capacitance reference sample (Cat. No. 19006352)

Quick daily check

Power up the analyzer. With the measuring cell empty

Press



After 6 seconds

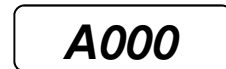

Indicates for empty cell, weight and capacitance are within limits.

If any of these measurements are out of tolerance, the instrument should be reset. Please contact Sinar Technology for instructions.

Tel: + 44 (0) 844 745 1999 or e-mail sevice@sinar.co.uk

Sinar Model 6060 Analyzer

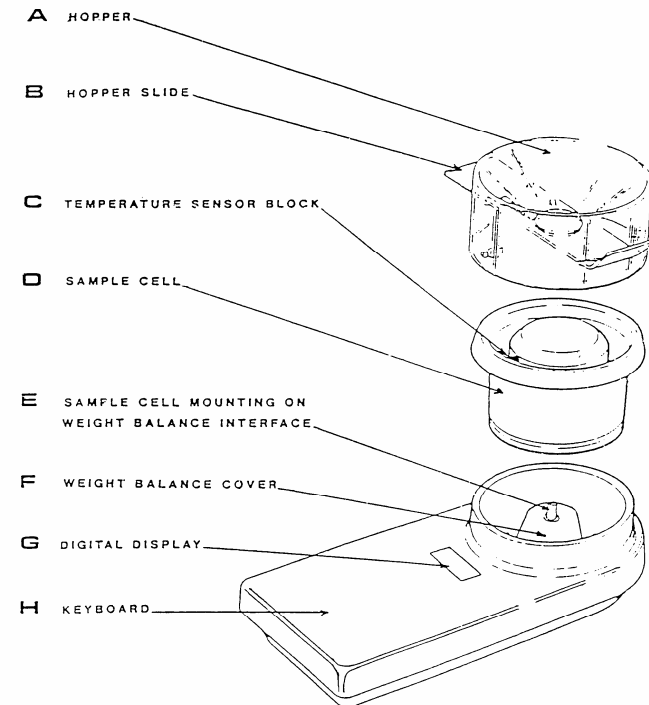

Figure 1

Keypad

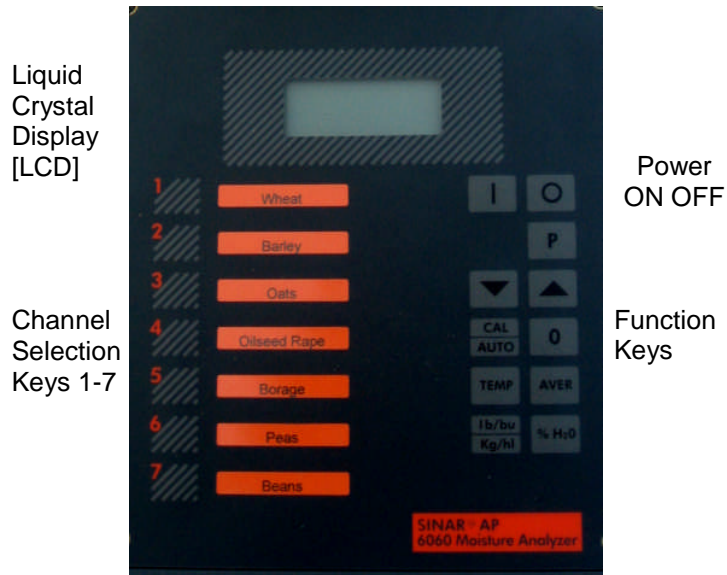

Figure 2

Calibration Changes/Updates and Logging Facilities

Your Sinar Model 6060 Moisture Analyzer is a very powerful portable instrument having features normally associated with larger more expensive units. The microprocessor and RS 232C communication port enable data transfer.

Calibration Transfer.

Calibration data is held inside the microprocessor as a comma separated file [csv extension file]. These file can be uploaded or downloaded using a Windows environment piece of software Part Number 19006940. Files can be sent over the Internet either for checking, changing or updating thereby eliminating "return to base" of the unit.

Data Logging.

Using the data transfer port the Sinar Model 6060 can be connected to a computer in hyperterminal mode for continuous logging of measured result.

It is preferable to use Sinar MLog software Part Number 19006362 although other propriety data collection software can be used.

For further information on these facilities and products contact Sinar Technology or your local distributor

Hectolitre (Bushel) Weight adjustment

In the same way as moisture content can be adjusted, the hectolitre weight results can be matched to read the same as either another instrument [such as a chondrometer] or a reference sample.

As for the adjustment of moisture, it is **important** that the hardware settings are correct, particularly the weight balance, before any hectolitre [bushel] weight comparisons or any subsequent adjustments are made.

Power up the analyzer

- HI -

Select Channel No. (1-7) e.g. 1

1

P

Press
And
Hold

⌈ CAL

Using the arrow keys to make the adjustment necessary for the particular product, e.g. if readings are to be adjusted by 0.5kg/hl

0.5

Press ▲ 5 times

CAL
AUTO

Press
And
hold

End

The adjustment is now complete.

To check the adjustment press and hold the

P

key

followed by a further press only

Measurement cell

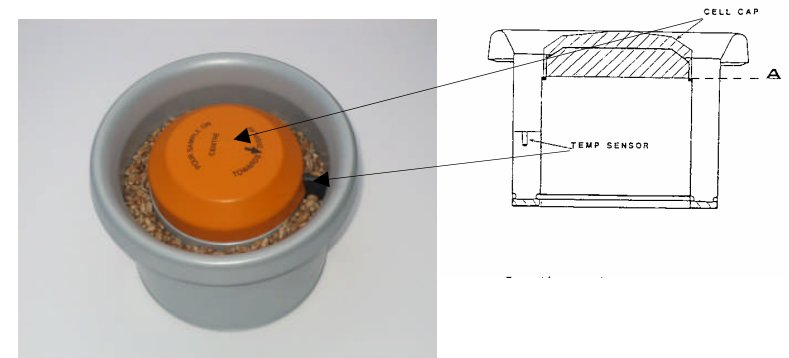

Warning: Do not overfill see Notes 1-4 below

Notes:

1. For optimum reading the cell should be filled to level A
2. The sample should not cover the orange cell cap or inaccuracies will occur.
3. Sample should cover temperature sensor to ensure temperature compensation and accuracy.
4. Minimum sample weight is 20 gm. But at reduced accuracy .

Figure 3

The Theory

The moisture content of a sample is defined as the ratio of mass of free water to the total mass of the sample, and is generally found by weighing the sample, dehydrating it, and re-weighing.

$$\%MC = \frac{\text{Initial Mass} - \text{Final Mass}}{\text{Initial Mass}} \times 100 \quad \text{or} \quad \%MC = \frac{\text{Wet Mass} - \text{Dry Mass}}{\text{Wet Mass}} \times 100$$

It is also possible to measure the moisture content indirectly using the electrical properties of water. This does, in theory, give much quicker readings and speeds up the analytical process. Developing instrumentation that measures these indirect electrical properties is Sinar Technologies business and speciality.

Sinar Technology instrumentation uses the relationship between moisture content and the samples dielectric constant as the basis of measurement. It has been noted for many years that the variation of the dielectric constant of hygroscopic materials against moisture content is approximately linear over a limited but useful range of 1% - 35% moisture content.

The dielectric constant of water is 81, whereas the dielectric constant of most materials of vegetable origin is quite low, ranging from 2.2 to 4.0 in a dry condition. The presence of a very small quantity of water in the material will, therefore, cause a considerable change in the dielectric constant.. This direct link between Moisture Content and dielectric content enables Sinar Analyzers to predict, successfully the Moisture Content of a wide range of samples.

The Problems

The relationship between moisture content and dielectric constant is complicated by several factors. The problems and the solutions that Sinar Technology applies to them can be summarised thus:

Problem: Inconsistent and high sample temperatures that inherently change the dielectric constant of samples.

Solution: Measure the sample temperature and the dielectric constant simultaneously and compensate accordingly.

CALIBRATION ADJUSTMENT

The Sinar Model 6060 comes pre-calibrated with authorised commodity calibrations. Sometimes it is useful to be able to adjust the moisture reading. For instance when a different oven test is used or when the particle size of a product is significantly different or when two indirect instruments are being matched against each other.

Warning: Some calibrations are factory biased on delivery. Any factory calibration should only be changed with **extreme caution** as it will change the meter tolerances for accuracy.

DO NOT make any adjustment before verifying the hardware settings are correct. See page 18.

Always determine the average adjustment needed by comparing at least three different oven tested samples.

If in doubt contact Sinar Technology for advice before making the adjustment.

Adjustment of moisture content

Select Channel for adjustment e.g. 3



Press
And
Hold



Press
And
Hold



Fill cell with a sample and
Press

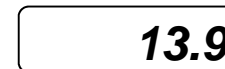

Using the ▲ key, press x 3 to make an adjustment of +0.3%mc

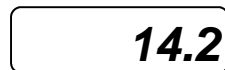

Press
key

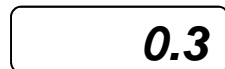

PRINTER FUNCTIONS (cont.)

To print average or hectolitre weight press appropriate keys.

Note: If you are not using the printer, ensure the printer mode is turned off in the analyzer. A flashing colon [:] on the display indicates the printer mode is ON when the printer is NOT connected.

Entering an Identification Number [Batch No.]

This is a useful facility to identify measured samples. To key in identification using Channel keys 1-7 e.g. 485 for print out together with the measured result.

Select **CAL** mode. (See pg 13.)

Press 4

C 4

Press 7

C 47

Press ▲ once

C 48

Press 5

C 485

AVER

Press key

b 485

Return to measuring mode by pressing CAL or turning OFF and ON

- HI -

Problem: Uneven distribution of water throughout the sample.

Solution: Calibrate using typical samples in the state that they will be measured in practice. For example pre-dried or even freshly harvested.

Problem: Packing density of the sample

Solution: By filling the measurement cell to the same height every time the volume of the sample is kept roughly constant and using the loading hopper improves consistency of packing density. Measurement of the sample mass also enables the unit to automatically compensate for differences in sample volume. See Figures 1 & 3

Problem: Other chemical and physical parameters within a given sample, for example shape, size, protein content etc.

Solution: Sinar Technology develops individual calibrations for each significantly different species or differently grown sample of the same species.

Calibrations

Before any readings can be taken in the field using a Sinar Analyzer, a robust calibration must be established for the commodity to be measured. How this achieved?

First, obtain samples of the commodity to be measured, which vary in moisture-content one from another. For a variety of wheat, take at least 10 samples differing from each other by at least 1% moisture content. Obviously, moistures depend upon the availability of samples and the moisture range over which you wish to measure.

The samples must be measured accurately using the reference method laid down for that particular commodity. This reference method will vary from sample to sample and country to country. Consult Sinar Technology if you require any assistance finding reference methods for a given commodity.

The samples are then placed, in turn, into a Sinar moisture meter and the capacitance (dielectric constant) reading is taken.

Calibrations (continued)

A calibration curve is then constructed of Sinar capacitance reading against reference moisture content for each sample. This can be greatly simplified by using the Sinar MoistureNet calibration software to automatically predict a calibration curves.

Note:- In most cases, Sinar Technology is able to supply the Moisture Analyzers ready calibrated to individual requirements. We have over 25 years of calibration experience in many different commodities and countries. Common **pre-calibrated curve sets** are:

- 001 Wheat, Barley, Oats, Oilseed Rape, Linseed, Peas & Beans
- 002 Maize, Wheat, Barley, Oats, Rye, Oilseed Rape & Sunflower
- 003 Rice, Sorghum, Millet, Maize, Barley, Soybean & Ground Nuts
- 004 Wheat, Barley, Rice (short), Rice (med), Rice (long), Oats & Sorghum
- 005 Maize, Soybean, Oilseed Rape, Sunflower, Lupin, Ground Nuts & Palm Oil Kernel
- 006 Beans, Peas, Chickpeas, Lentils, Soybean, Hericot Bean & Kidney Bean
- 007 Almonds, Brazil Nuts, Cashew Nuts, Hazel Nuts, Pecans, Peanuts & Walnuts
- 008 Pimento, Cloves, Turmeric, Black Pepper Corns, Dried Root Ginger, Cocoa Beans & Green Coffee beans
- 009 Tea (Large leaf), Tea (Small leaf), Green Coffee Beans, Parchment Coffee, Dry Cherry Coffee & Cocoa
- 010 Wheat, Barley, Oats, Lupin, Canola, Peas & Rice

What is the unit doing when taking a measurement?

The instrument takes three separate readings and correlates the information ready to be processed by the instrument's microprocessor. These three readings are:

The **mass** of the sample is measured: An oscillating, inertia weight balance performs this role. The measurement is carried out automatically in seconds and the reading used to help compensate for varying sample.

The **temperature** of the sample is measured: A thermistor located within the sample cell, measures sample temperature several times and the values are compared within the microprocessor. If the temperature is found to be varying then the analyzer waits, takes further readings and the message "**soon**" is displayed. Such a method reduces errors if warm or cold samples, (with rapidly changing temperatures) are placed into the analyzer.

PRINTER FUNCTIONS

Data from your Sinar Model 6060 Moisture Analyzer can be outputted to either a serial printer [Part number 19006221] or a computer.

Connection to serial printer

- Connect cable Part Number 19006412 to the 5 pin DIN socket on the left-hand side of the analyzer and the 25 way connector on the printer.
- Switch on the Printer and Moisture Analyzer
- Select **CAL** mode



Hold Down Key



Press Key



Press key



Measured results will now be transmitted over the interface to the printer. Results are date and time stamped in real time. If required a batch number can be entered to identify measured samples

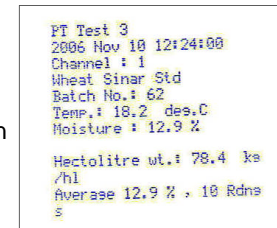

To STOP print out mode



Hold Down Key



Press key



Error messages

Indicates the sample is less than 20gms
Action: Use larger sample

Err. 0

Indicates the sample cell is not properly mounted.
Action: Remount sample cell firmly on to interface

Err. 1

Indicates capacitance too high [2] or low [3].

Err.2

Action: Check hardware; maybe in need of re-calibration or adjustment.

Err.3

Contact Sinar Technology or your local dealer

Indicates high [4] or low [5] moisture being incorrectly predicted by calibration

Err.4

Action: Check hardware; maybe in need of re-calibration. Check calibration software; adjustment required.

Err.5

Contact Sinar Technology or your local dealer

Communication error in RS232C

Err.6

Action: Check cable and re-start

The **capacitance** (dielectric constant) is measured. The capacitance reading is corrected for temperature and mass and the resultant value is applied to the selected commodity calibration curve, which predicts the true moisture content.

Moisture Measurement

1 Fill the Cell with Sample

- Place hopper on cell
- Close the slider
- Fill Hopper with sample
- Tap slider upwards, so that the sample flows into the measuring cell
- Remove hopper
- Do not shake cell during or after filling
- If sample does not flow easily, e.g. flour, use a brush or the special hopper for light material (Part No. 19006170)



For key locations, see page 4 Figure 2 Keypad.

Key	LCD
Select Channel Number Select channel, e.g. No.2	C 2
Moisture Measurement Press  After 3 seconds	read

Note: If you press and hold down the %H2O key **log** will be displayed. This is because you have placed the unit into logging mode. See pg 10 & 17

Moisture Measurement (continued)

result is displayed within 6 seconds

13.2

Moisture measurement in **Log** mode

Pressing and holding %H2O key will place the analyzer into logging mode, displaying **Log** on the LCD. An ASCII string is outputted via the RS232 port to a computer or serial printed every time the %H2O key is subsequently pressed. To switch the logging function **off**, press and hold the %H2O key until **-Log** is displayed.

Other Functions

Average Moisture

AVER Hold
Down
Key

number of measurements

10

Release
Key

average moisture

13.3

Note: Maximum of 254 samples can be averaged

To reset the average, switch the analyzer OFF and ON or change channel

Sample Temperature

TEMP Press
Key

21.1

Units can be set to °C or °F [factory default is °C]

Bushel/Hectolitre/Test Weight

By using the 19006155 weight measuring cylinder the density of the sample can be measured

- Place the hopper on the black top plate
- Ensure the slider is closed on the hopper
- Fill the hopper to it's maximum
- Ensure the slider on the cylinder is open
- Release the slider on the hopper
- Grain must fill and overspill the cylinder
- Close the slider on the cylinder
- Remove hopper and discard excess grain



lb/bu
kg/hl Press
Key

78.2

Units can be set to lb/bu or kg/hl [factory default is kg/hl]

Display messages

Indicates lapse of 12 months since analyzer has been serviced.

Note: When Ser. Is displayed the analyzer is still fully functional press any key to continue.

Ser.

Indicates low voltage; requiring change of batteries within next 50 hours.

Batt.

Indicates suppression of moisture result due to a difference between sample and cell temperature. [See page 9]

Soon

Depending on temperature difference this maybe followed up to a 7 second delay indicated by a countdown 7- 1 until the result is displayed

7

e.g. rapid cooling a sample taken from a commercial dryer or process at elevated temperature

14.6