



www.qclabequipment.com



910-sT SMART Touch Moisture Analyzer Continuous On-line Moisture Measure and Control System

- On-Line Analysis on Moving Webs, Flat Belt Conveyors, Screw Conveyors, or Lab use
- Moisture Content shown on Touch Screen PC-XP
- Calibration factors entered on program window
- Loss of Product switch shows no product at sensor
- Analog 4—20 mA output for logging or control
- On screen chart shows moisture for past 1 hour
- Programmable smoothing for accurate readings



Moisture Register Products introduces the new Model 910-sT Smart Touch Screen IR Moisture Analyzer. Moisture results are continuous, instantaneous and non-destructive. Process outputs are available to provide automatic moisture control and data logging.

Near Infrared Sensor

- Nondestructive moisture sensing in the 0 to 60% range
- Filtration of reflected energy from sample reduces ambient light and color considerations
- Simplified optics, no mirror or lenses to align
- Stable quartz halogen NIR sensor
- Drift-free temperature stability
- Auto ranging is used to adjust the NIR Sensor output to an optimum level for reliable processing

VERSATILITY

paper · plastic pellets · briquets · snack foods · crumb rubber · fish meal · corn meal · detergent · soy meal · coffee · gypsum board · carpet · powders · ceiling tiles · wallboard · wood fiber · sawdust · foundry sand · pharmaceuticals · ceramic powders · milk powder · tiles · and more

www.qclabequipment.com



QAQC LAB

www.qclabequipment.com

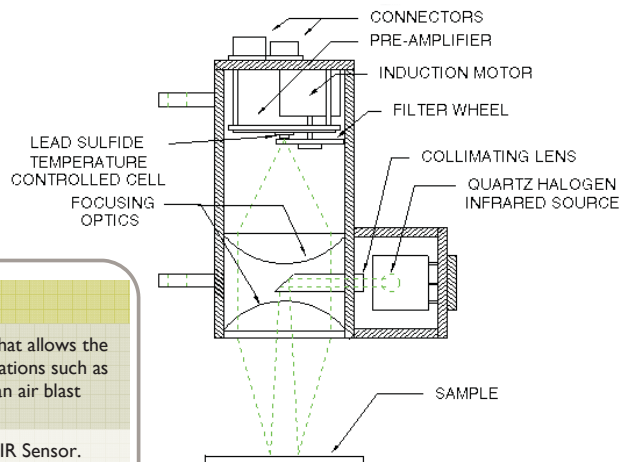

NIR Sensor

Optional Features

Opto-Port Attachment for NIR Sensor	This stainless steel attachment is a Patented Mounting Device that allows the NIR Sensor to adapt to a variety of difficult sample handling situations such as screw conveyors and free fall conveyors. Can be ordered with an air blast system for free falling samples.
Dust Shield	For dusty environments. Prevents the build-up of dust on the NIR Sensor. Requires a constant flow of clean, dry air.
Explosion Proof Housing for NIR Sensor	Call for a quote.
Cooling Jackets and Housings	Keeps sensor temperatures within an acceptable range in high temperature environments.
NIR Test Plate	Used to verify a repeatable calibration signal.
Low Profile NIR Optical Attachment	Allows for the NIR Sensor to be mounted at locations where the clearance is not adequate to mount the normal NIR sensor.
RF Link	Permits a wireless communication from the remote location of the SMART II console to a local display and output console.

Console Specifications

Moisture Range	Minimum 0 to 0.1%, Maximum 0 to 60% (wet weight)
Accuracy	± 0.02% to 0.2% depending on product and moisture range being measured
Repeatability	3 parts in 4096
Stability	One calibration per year
Smoothing Constant	0 to 37 seconds. Integration after initial buffer fill.
Calibration	Up to 7 points define calibrated moisture range
Calibration Tables	Download as required from PC
Update Rate	7 moisture calculations per second (28 optional)
Ambient Operating Temperature	0 to 50°C
Relative Humidity	0 to 90 percent non-condensing
Storage Temperature	-18 to 80°C
Dimensions & Weight	12" x 13 1/2" x 6" (305mm x 343mm x 152 mm) 28lbs (12.7 kg)
Power Requirements	120 VAC 60 HZ or 230 VAC 50/60 HZ, 120 VA
Inputs	NIR or RF Sensor; High Voltage Isolated
Outputs	<ul style="list-style-type: none"> · Isolated 4 to 20 mA · Span adjustable · Loss of Product Alarm · Data is in ASCII format for simple interface · Isolated Serial Data Port, RS-232C (RS-485 optional)

Sensor Specifications

Operating Temperature	Maximum: 122°F/50°C Minimum: 30°F/0°C
Storage Temperature	Maximum: 176°F/80°C Minimum: 0°F/-18°C
Lens Distance to Product	9" (228mm) ± 1" (25mm)
Sampling Area	0.39" square (10mm square)
Penetration depth	Up to 1mm (dependent on material)
Dimensions & Weight	14 1/2" x 10 1/2" x 5.375" (368mm x 266.7mm x 137mm); 13 1/2 lbs. (6.1 kg)

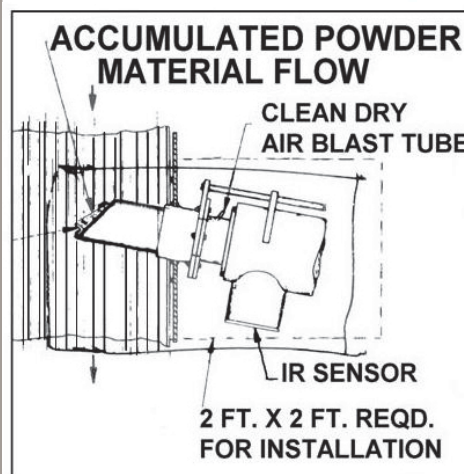

Opto Port for use on pneumatically conveyed materials vs. the Opto Port with clean dry air blast.

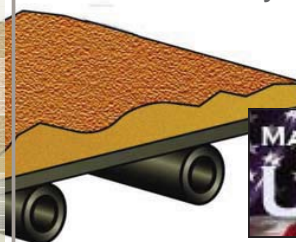

MOISTURE REGISTER PRODUCTS



QAQC LAB

www.qclabequipment.com