



# MOISTURE BALANCE

CSC NOS. 26680-000 AND 26680-008

## 1 INTRODUCTION

The CSC torsion-type Moisture Balance is an instrument for measuring the moisture content of materials that maintain their chemical structure while drying under infrared radiation. The balance displays a continuous percentage reading of the loss of weight due to the loss of moisture. Since drying and weighing are simultaneous, this instrument is especially useful in measuring the moisture content of substances that quickly reabsorb moisture.

Some of the more common products that are frequently tested with this instrument include cereal grains, chemicals, clay, dry milk, dry sugar beet pulp, fertilizers, flours, hay, leather, pharmaceuticals, resins, soy bean products, starch, and sewage.

The CSC Moisture Balance is available in two models: No. 26680-000 for 115-volt, 50-60 Hz. operation; No. 26680-008 for 230-volt, 50-60 Hz. operation.

The instrument, as shipped, is equipped with a torsion wire for approximately 5-gram samples. Supplied unmounted are additional torsion wires for approximately 25-gram and 100-gram sample measurements. For torsion wire conversion refer to Section 6.

A package of 25 disposable pans for solids (CSC No. 26678) is also supplied.

## 2 SPECIFICATIONS

Sample Capacity, grams	
With 0.016-inch diameter wire installed . . . . .	Approx. 5
With 0.024-inch diameter wire installed . . . . .	Approx. 25
With 0.033-inch diameter wire installed . . . . .	Approx. 100
Scale Graduations . . . . .	0.2%
Readable Accuracy . . . . .	±0.2%
Input Voltage	
No. 26680-000 115-V, 50-60 Hz.	
No. 26680-008 230-V, 50-60 Hz.	
Dimensions, inches; both Models	
Height . . . . .	14
Width . . . . .	12
Depth . . . . .	14
Weight, pounds; both models . . . . .	24

*Base Cover* - Protective cover for components in instrument base, it forms part of drying chamber.

*Lamp Housing* - Pivoted atop the base cover, this housing for the heat lamp forms part of the drying chamber. It can be raised and lowered as required.

*Heat Control Dial* - Regulates heat controller which controls heat output of infrared heating lamp. (Also on-off switch)

*Scale-Lamp On-off Toggle Switch* - To illuminate readout port when desired.

*Readout Port* - Window at which all adjustment functions are observed and readings taken.

*Balance Arrest Control* - It prevents damage to balance in transit and when not in use.

The following items are integrally related both physically and functionally.

*Pointer* - Fixed to torsion wire, it indicates relative torsional displacements.

*Scale* - Fixed to torsion wire, it also indicates relative torsional displacement.

*Fixed Index Line* - A fixed metal strip which contains a scribed line and functions as a fixed reference point for balance mechanism.

*Initial Calibration Knob* - It applies torsion to wire for zeroing instrument when disposable pan is in place but before sample material is added.

*Scale Adjusting Knob* - It rotates scale and simultaneously applies torsion to wire.

*Retainer Pan* - It pivots at its center on hardened cone point of lever arm fixed to torsion wire. It acts as support for disposable pan.

## 4 SET-UP

Set the Moisture Balance on a stable, even surface that is reasonably level. Raise the lamp housing and remove any packing material. Plug the three-prong connecting cord into a mating outlet of proper voltage rating. The instrument is now ready for operation.

## 5 OPERATION

### 5.1 Procedure for Maximum Precision

- (1) **Raise the lamp housing.**
- (2) **Turn lamp on to illuminate readout port.**
- (3) **Retract balance pan arrest.** Lift knurled knob and turn clockwise until arm completely clears pan and comes to rest on housing.
- (4) **Set disposable pan (CSC No. 26678) on to retainer pan.** Hole of pan should pass over post of retainer.
- (5) **Bring the 100 percent mark of scale to coincide with fixed index line by means of the scale adjusting knob.**
- (6) **Bring the movable pointer to coincide with the index line by means of the initial calibration knob.** Turn knob clockwise if pointer is below index, counterclockwise if above.
- (7) **Return the 0 percent line of scale to coincide with index by means of scale adjusting knob.**
- (8) **Place sample material on disposable pan.\*** Distribute material evenly to maintain pan reasonably level and in sufficient quantity to bring pointer into coincidence with index.
- (9) **Lower the lamp housing.**
- (10) **Turn heat lamp on by pushing in Heat Control Dial.**
- (11) **Adjust heat control dial.** (Refer to section 5.2 for proper heat setting.) As moisture evaporates, pointer will rise above index line.
- (12) **Periodically rotate scale adjusting knob clockwise to maintain pointer in close proximity to index line.** When pointer stops rising, drying is complete.
- (13) **Bring pointer into exact coincidence with index by means of scale adjusting knob.**
- (14) **Take final direct reading from scale line which is now coincident with index line.** This completes the test.
- (15) **Heat lamp may be shut off, lamp housing raised and disposable pan with sample material removed and discarded.** You are now ready to repeat the above steps for another test.

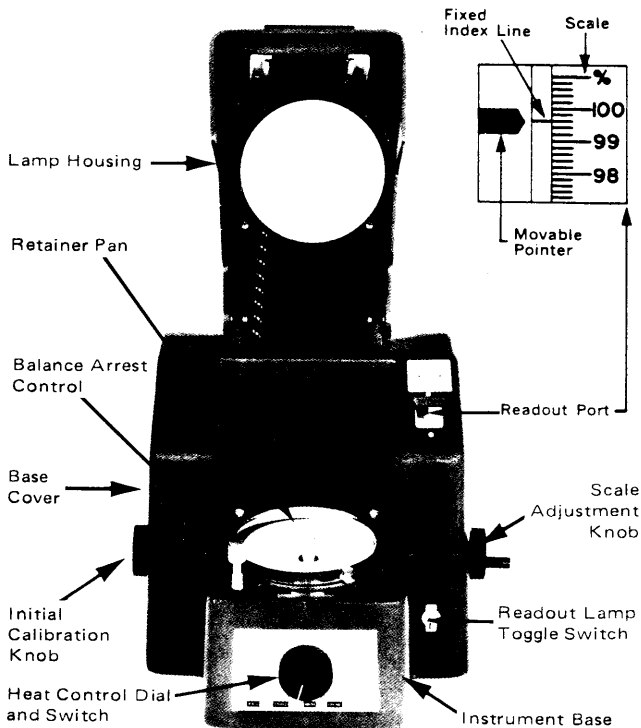

Fig. 1. CSC Moisture Balance.  
Inset shows detailed view of readout port.

### 5.2 Procedure for Determining Proper Heat Setting

Place a sample of the specific material to be tested on the sample pan. Set the heat control at an arbitrary setting and turn on the infrared lamp. Observe the results.

Discoloration or smoking of the sample, caused by excessive heat, indicates the release of volatile matter other than moisture, and erroneous measurement results. Repeat the trial at a reduced setting until the proper drying temperature is determined. If the arbitrary setting is *below* the proper drying temperature, accurate results are still obtained but valuable time is lost due to the prolonged drying time.

### 5.3 Procedure for Maximum Speed

If time is extremely important and if results of greatest accuracy are not required, the following procedure is recommended. This procedure involves the preparation of several drying curves, each curve being for a sample of the same material but each sample having a different initial moisture content. Plot moisture content (as ordinates) against elapsed time (as abscissae) and record the readings at measured time intervals - for example, every five minutes. For each curve determine the ratio of the final moisture content to the moisture content found after five minutes of drying time. This ratio, greater than unity, should be approximately the same for each curve.

Average the several ratios to obtain a factor by which the reading obtained after five minutes of drying time can be multiplied to obtain the total moisture content of the sample.

This method is applicable for samples where the range of moisture content is small. If a large range is to be covered, several factors should be determined and used. It is to be expected that a different factor must be determined for each different material.

### 5.4 Procedure for Determining % of Moisture on a Dry-Weight Basis

The percentage of weight reduction read from the scale is the percentage of moisture lost, based on the initial weight of the sample. In some cases it may be desirable to obtain the percentage of moisture based on a dry sample. This can be readily computed from the formula:

$$P^1 = \frac{100P}{100 - P}$$

where *P* is the percentage of moisture lost by the sample, and *P*<sup>1</sup> is the percentage of moisture on the dry basis. The formula can be applied as needed to individual cases, or it can be used to make a chart showing *P*<sup>1</sup> for different values of *P*.

### 5.5 Instrument Accuracy Check

Periodically you may wish to check the instrument's accuracy. To this end, follow the same operating instructions as outlined in Section 5.1. Only, this time, instead of the CSC No. 26678 pan supplied with the instrument, use a CSC No. 26679 Disposable Pan for Liquids. And instead of your regular sample material, use distilled water. Proceed until the water is completely evaporated. At the conclusion of the test, when the pointer is brought to the index, the scale reading at the index should be 100%.

## 6 MAINTENANCE

With normal care and under proper usage, the CSC Moisture Balance will give reliable service over a period of many years. When it becomes necessary to replace the torsion wire, the following procedure is suggested.

Notice that the upper and lower parts of the balance housing are held together by four machine screws. Two of these screws are in the sample compartment and the other two are in the rear of the housing. Remove these screws, (a) in Fig. 2, and carefully lift the upper part. Since the upper and lower parts are joined electrically through a three-prong plug and socket (e) at the rear of the housing, it is necessary to pull the plug from the socket (e) as the upper part is raised. Index the scale (j) to the 100% mark and rotate the pointer gear (f) so that the slots in the clamp screws are accessible. Remove screw (b) and insert it into the slotted portion of the spring assembly (d). Tighten screw (b) until the torsion wire (h) is relieved of all tension. Loosen screws and clamps (c), which fasten wire (h) to the pan support and torsion wire bridge (g) and on each end of the wheel assemblies. Remove the torsion

wire (h). Replace the torsion wire with either CSC No. 26681-011 5-gram torsion wire or No. 26681-022, 25-gram torsion wire. Being careful to avoid kinking or twisting it, thread the new torsion wire through the scale wheel hub (i), between clamp (c) and arresting arm (g) and through the gear wheel hub and spring assembly (d). Leave about 1/2 of an inch of wire protruding from each clamp. Clamp the wire at the scale-wheel side of the balance, being sure the wire is in the "V" groove. Pull the wire taut and clamp it to the spring assembly (d). Remove the spring release screw (h) and washer, and replace them on the housing cross section. Center the pan support and torsion wire bridge (g) so that the pan moves freely in the retainer, and the pointer moves as closely as possible to the index without rubbing. See that the damping cone moves freely between the poles of the magnet. Clamp the wire to the bridge.

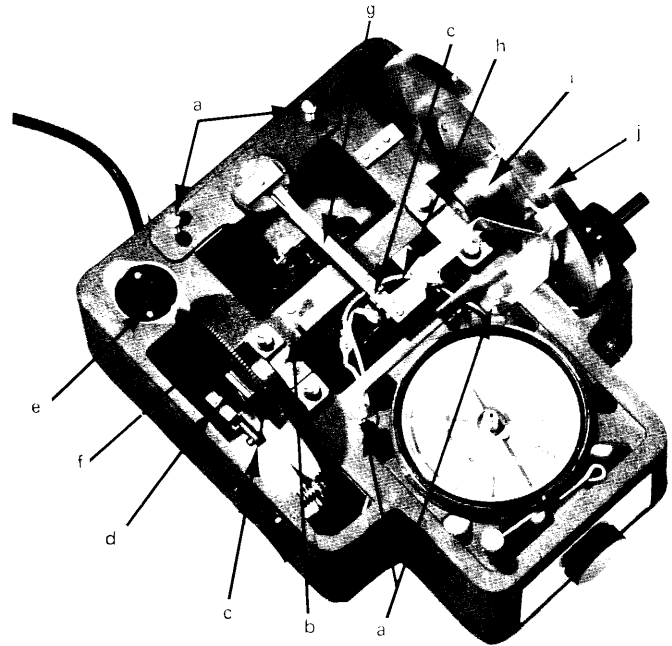

- (a) Machine screw
- (b) Machine screw
- (c) Screws and clamp
- (d) Spring assembly
- (e) Socket
- (f) Pointer gear wheel
- (g) Torsion wire bridge
- (h) Torsion wire
- (i) Wheel hub
- (j) Scale

Figure 2. Top view of the Moisture Balance with the upper housing removed to reveal the mechanism.

If difficulty occurs which cannot be corrected immediately contact the CSC office or your dealer's service department, giving all the necessary details. Do not return the balance or any of its parts for repair or replacement without written authorization from CSC.

## 7 REPLACEMENT PARTS AND ACCESSORIES

Description	CSC No.
Infrared lamp, 125 watts, 115 volts for 26680-000	26681-033
Infrared lamp, 250 watts, 115 volts for 26680-000	26587-000
Scale lamp, for No. 26680-000 balance, 115 volts	26681-001
Retainer pan	26677-000
Disposable pan for solids - Pkg. of 25	26678-000
Disposable pan for liquids - Pkg. of 25	26679-000
5 gram torsion wire - Pkg. of 3	26681-011
25 gram torsion wire - Pkg. of 3	26681-022
100 gram torsion wire - Pkg. of 3	26681-044